



WALL



Stromversorgung.....	220 V - 50 Hz
Stromverbrauch (Watt).....	18,4
Anschluss Wasserseitig.....	ø 8 x 1 mm
Modell.....	Wanddispenser
NETTOGEWICHT kg.....	15
BRUTTOGEWICHT kg.....	17
Abmessungen L x B x H (mm).....	263 x 114 x 900
Versandmaße (mm).....	294 x 143 x 930
Material.....	Edelstahlrahmen
	Frontpaneel aus eloxiertem Aluminium
	Professioneller hochwertiger Ventil
Versorgung.....	Wasser



OPTIONALES ZUBEHÖR

FILTER.....	Endständige UVC-LAMPE (intern)
WANDTRÄGER.....	✓

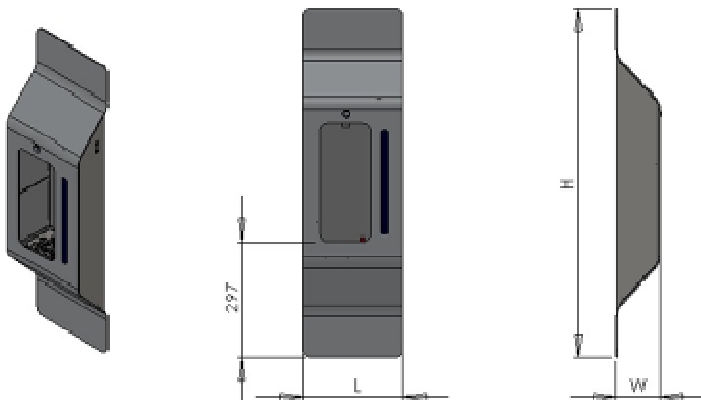

Anschließbar mit allen schon besitzten Einbaugeräten.

„WALL“ kann auch an einem Wasserspender angeschlossen werden.



Verbände:



Blupura Srl - Italy | T. +39 071 971 0080
info@blupura.com | www.blupura.com

Blupura USA Inc. - USA | T. +1 305 777 3591
blupurausa@blupura.com

Zertifizierungen:

